



## Shandong Jinjie Machinery Co.,Ltd

Addr: 253000, #438, North Hubin Road, Tianqu Industrial Park, Dezhou, Shandong, China

Tel: +86-534-2356966 Fax: +86-534-2356966

Email: [sales@jinjie-machinery.com](mailto:sales@jinjie-machinery.com); [sophie@jinjie-machinery.com](mailto:sophie@jinjie-machinery.com)

### Jinjie Precision Vise Series

#### 1. JJ-00332 QGG Precision Tool Vise

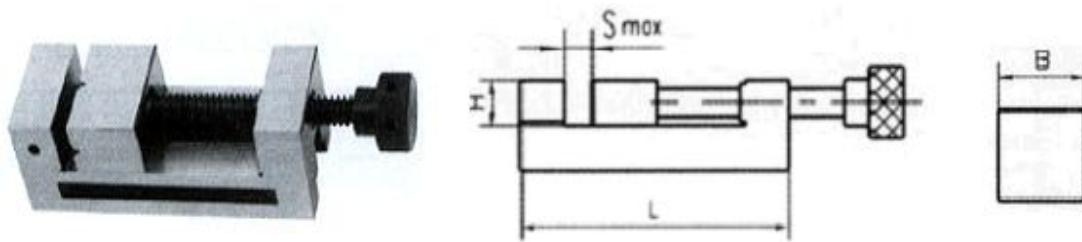

Model	B(mm)	H(mm)	Smax(mm)	L(mm)	Wt(kg)
QGG50	50	25	65	155	3.0
QGG60	60	25	55	110	2.4
QGG63	63	32	85	190	3.8
QGG73	73	35	100	210	5.0
QGG80	80	40	100	220	6.5
QGG88	88	40	125	250	11.0
QGG100	100	45	125	260	13.0
QGG125	125	50	160	300	19.5
QGG125A	125	50	210	350	23.0
QGG150	150	50	175	315	23.8

#### 2. JJ-00334 Precision Tool Vise

1. Made of high-quality alloy steel, after heat, precision ground, parallelism and squareness within 0.005/mm.

2. Available inspecting angles and processing workpieces with angle.

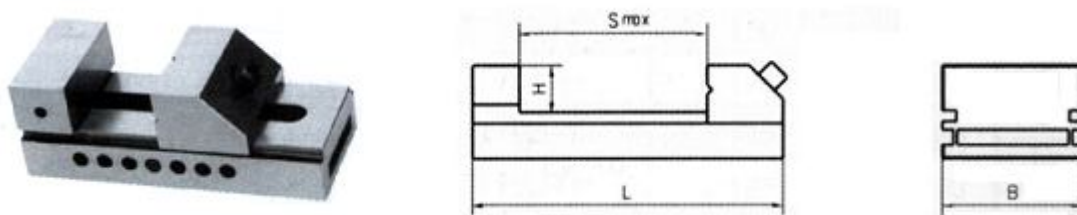

<http://www.jinjie-machinery.com/>



## Shandong Jinjie Machinery Co.,Ltd

Addr: 253000, #438, North Hubin Road, Tianqu Industrial Park, Dezhou, Shandong, China

Tel: +86-534-2356966 Fax: +86-534-2356966

Email: [sales@jinjie-machinery.com](mailto:sales@jinjie-machinery.com); [sophie@jinjie-machinery.com](mailto:sophie@jinjie-machinery.com)

Model	Bmm	Hmm	Smm	Lmm	Wt(kg)
QKG25	26	9.15	22	65	0.5
QKG36	36	20	40	100	1.2
QKG38	38	20	44	105	1.3
QKG50	50	25	85	140	2
QKG63	63	32	85	175	3
QKG73	73	35	100	190	4.1
QKG80	80	40	100	200	5.56
QKG88	88	40	125	130	7.36
QKG100	100	45	125	240	10
QKG125	125	50	160	285	18
QKG150	150	50	200	330	21.5
QKG150A	150	50	250	380	23
QKG150B	150	50	300	430	24

### 3. JJ-003350 QGJ Precision Sine Tool Vise

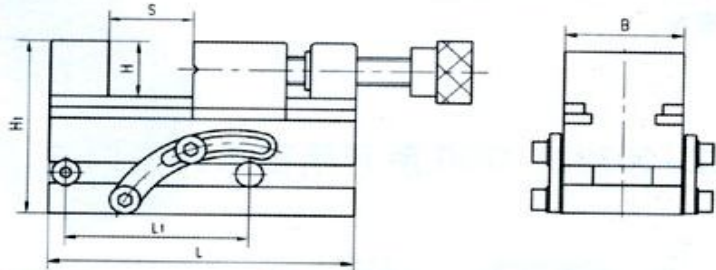

Model	B(mm)	H(mm)	H1(mm)	Smax(mm)	L(mm)	L1		Adjustable angle range
						mm	in	
QGJ50	50	25	89.6	60	140	100	5	0~45
QGJ63	63	32	94.6	85	175			
QGJ73	73	35	111	90	190			
QGJ80	80	40	121	95	200			
QGJ88	88	40	125	120	235			
QGJ100	100	45	139.2	125	245			
QGJ125	125	50	154.2	160	285	200		



## Shandong Jinjie Machinery Co.,Ltd

Addr: 253000, #438, North Hubin Road, Tianqu Industrial Park, Dezhou, Shandong, China

Tel: +86-534-2356966 Fax: +86-534-2356966

Email: [sales@jinjie-machinery.com](mailto:sales@jinjie-machinery.com); [sophie@jinjie-machinery.com](mailto:sophie@jinjie-machinery.com)

### 4. JJ-003352 QKJ Precision Sine Tool Vise

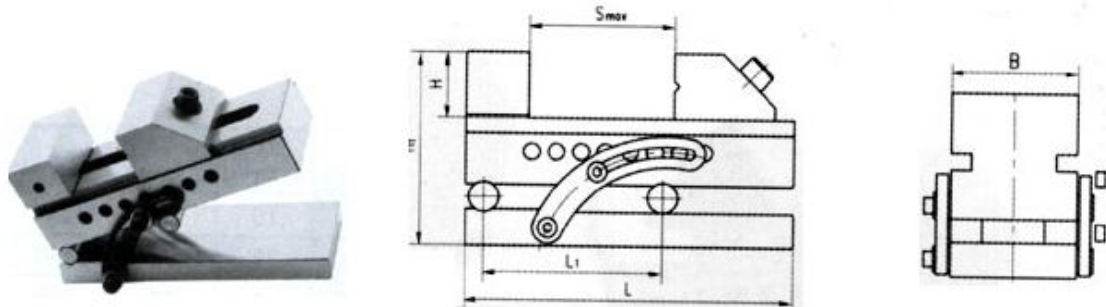

Model	B	H	H1	S	L	L1		Adjustable angle range
						mm	In	
QKJ50	50	25	79.36	65	140	100	5	0-45
QKJ63	63	32	92.36	85	175			
QKJ73	73	35	104	100	190			
QKJ80	80	40	117	100	200			
QKJ88	88	40	122	125	235			
QKJ100	100	45	134.08	125	245			
QKJ125	125	50	144.08	160	285	200		

### 5. JJ-003360 GT Precision Modular Vise

- 1、 Made of high-quality alloy steel
- 2、 The accuracy of vise (parallelism and squareness) is 0.005mm/100mm
- 3、 The hardness of working surface is HRC 58-62 and precision ground to a mirror finish
- 4、 It have interchangeable base , fixed/movable jaws it is quickly to clamp and easy to operate
- 5、 It is widely used on machine center and other precision machine tools

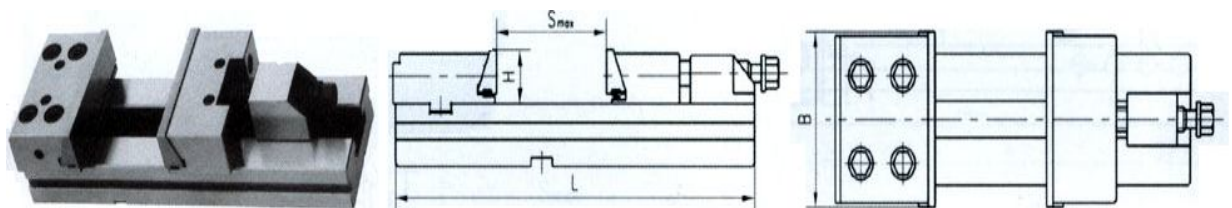



## Shandong Jinjie Machinery Co.,Ltd

Addr: 253000, #438, North Hubin Road, Tianqu Industrial Park, Dezhou, Shandong, China

Tel: +86-534-2356966 Fax: +86-534-2356966

Email: [sales@jinjie-machinery.com](mailto:sales@jinjie-machinery.com); [sophie@jinjie-machinery.com](mailto:sophie@jinjie-machinery.com)

Model	B(mm)	H(mm)	Smax(mm)	L(mm)	Clamping force(kg)	Wt(kg)
GT100-I	100	30	100	270	3000	7
GT125-I	125	40	150	345	3000	12.7
GT150A-I	150	50	200	420	5000	25.6
GT150B-I	150	50	300	520	5000	29.5
GT175A-I	175	60	200	455	6000	33.8
GT175B-I	175	60	300	555	6000	42.5
GT175C-I	175	60	400	655	6000	51.2
GT200A-I	200	65	200	495	10000	57
GT200B-I	200	65	300	595	10000	64
GT200C-I	200	65	400	695	10000	71

### 6. JJ-003362 Precision Modular Vise with Swivel Base

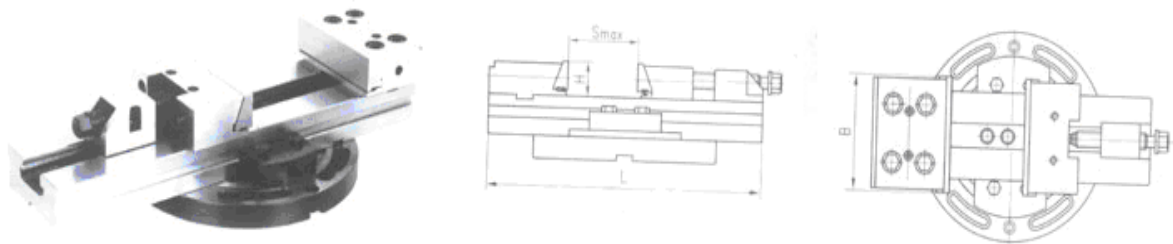

Model		Bmm	Hmm	Smm	Lmm	Clamping force	Wt(kg)
GT100	GT100-II	100	30	100	270	3000	10.3
GT110	GT125-II	125	40	150	345	3000	18.2
GT120	GT150A-II	150	50	300	420	5000	36.4
GT130	GT150B-II	150	50	200	520	5000	40.3
GT140	GT175A-II	175	60	300	455	6000	44.6
GT150	GT175B-II	175	60	400	555	6000	55.5

<http://www.jinjie-machinery.com/>



## Shandong Jinjie Machinery Co.,Ltd

Addr: 253000, #438, North Hubin Road, Tianqu Industrial Park, Dezhou, Shandong, China

Tel: +86-534-2356966 Fax: +86-534-2356966

Email: [sales@jinjie-machinery.com](mailto:sales@jinjie-machinery.com); [sophie@jinjie-machinery.com](mailto:sophie@jinjie-machinery.com)

### 7. JJ—003372 Quick Action Precision Modular Vise with Swivel Base

- 1、 Made of high-quality carburizing alloy steel
- 2、 Parallelism and squareness within 0.005/100mm
- 3、 Locate position by pilot pin, adjust pin on body according to opening size, then clamp quickly
- 4、 It is widely used on machining centers and other precision machines

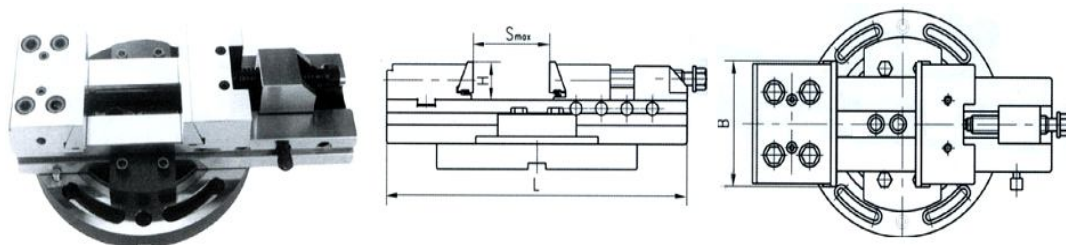

Model	B(mm)	H(mm)	Smax(mm)	L(mm)	Clamping force(kg)
GT125-IV	125	40	150	345	3000
GT150A-IV	150	50	200	420	5000
GT150B-IV	150	50	300	520	5000
GT175C-IV	175	60	400	655	6000

### 7. JJ—003420 QH Machine Vise

1. Made of high-quality cast iron.
2. Accuracy 0.025mm/100mm.
3. Widely used on milling and drilling machine tools in making some kinds of slots, holes and faces.



Model	Jaw Width	Jaw Height	Max.Opening	GW./NW.	Packing Shape	L*W*H
	mm	mm	mm	kg		cm
QH80	80	30	65	30/28(4pcs)	Carton	48*29*13
QH100	100	35	80	42/40(4pcs)		56*31*14
QH125	125	40	100	18/17		33*19*17
QH160	160	52	125	43/41		45*25*23
QH200	200	63	160	58/56		48*27*24

<http://www.jinjie-machinery.com/>