

BRIGHT-TOOLS

BRIGHT-TOOLS

CUTTING TOOLS

BRIGHT-TOOLS

BRIGHT-TOOLS

BRIGHT-TOOLS

BRIGHT-TOOLS

BRIGHT-TOOLS

BRIGHT-TOOLS

MILLING CUTTERS AND ARBORS

铣刀和刀杆

Face Milling Cutter, 43° 平面面铣刀盘, 43°	0.06
Face Milling Cutter, 45° 平面面铣刀盘, 45°	0.07
Face Milling Cutter, 75° 平面面铣刀盘, 75°	0.11
Face Milling Cutter, 90° 平面面铣刀盘, 90°	0.12
Face Milling Cutter, Round Inserts 仿形面铣刀盘	0.14
Face Milling Cutter, AMPT Inserts 方肩面铣刀盘	0.17
High-feed Face Milling Cutter 快进给铣刀盘	0.19
End Milling Cutter, Round Inserts 仿形立铣刀杆	0.22
End Milling Cutter, AMPT Inserts 方肩立铣刀杆	0.26
High-feed End Milling Cutter 快进给铣刀杆	0.28
Screw-in Milling Cutter, Round Inserts 仿形锁牙式铣刀	0.30
Screw-in Milling Cutter, AMPT Inserts 方肩锁牙式铣刀	0.33
High-feed Screw-in Milling Cutter 快进给锁牙式铣刀	0.35
OD Inserts OD单面正型8刃刀片	0.38
SN Inserts SN 双面加厚的负型8刃刀片	0.38
SE Inserts SE单面正型4刃刀片	0.39
HN Inserts HN双面负型12刃刀片	0.39
XN Inserts XN负型6刃刀片	0.40
ZN Inserts ZN负型6刃刀片	0.40
WN Inserts WN负型6刃刀片	0.41
RD Inserts RD 圆形刀片	0.41
RP Inserts RP 圆形刀片	0.42
AP Inserts AP两刃方肩铣刀片	0.43
SD Inserts SD 正型四刃刀片	0.43
LN Inserts LN 负型4刃刀片	0.44



BRIGHT-TOOLS

BRIGHT-TOOLS

BRIGHT-TOOLS

BRIGHT-TOOLS

BRIGHT-TOOLS

BRIGHT-TOOLS

BRIGHT-TOOLS

BRIGHT-TOOLS

CUTTING TOOLS

FACE MILLING

Face Milling Cutter, 43° 平面面铣刀盘, 43°

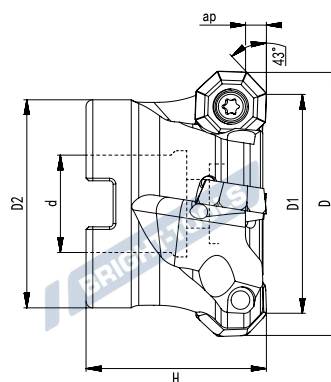
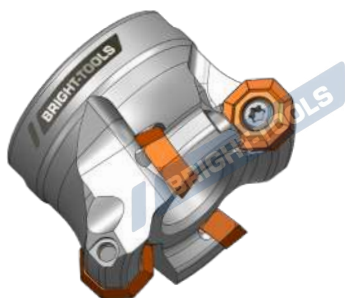

Size	D	D1	D2	d	h	z	ap	Internal Cooling	Stock
FM43-D50-22R-Z04-OD06	50	60	47	22	40	4	4	yes	●
FM43-D63-22R-Z05-OD06	63	73	47	22	40	5	4	yes	●
FM43-D80-27R-Z06-OD06	80	90	58	27	50	6	4	yes	●
FM43-D100-32R-Z07-OD06	100	110	75	32	50	7	4	no	●
FM43-D125-40R-Z08-OD06	125	135	88	40	63	8	4	no	●
FM43-D160-40R-Z10-OD06	160	170	100	40	63	10	4	no	●
FM43-D200-60R-Z12-OD06	200	210	130	60	63	12	4	no	○

Size	Insert	Screw	Wrench
FM43-D50...OD06...	OD..0605	M5x12	T20

Face Milling Cutter, 45° 平面面铣刀盘, 45°

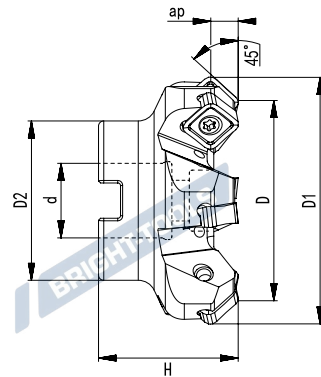

Size	D	D1	D2	d	h	z	ap	Internal Cooling	Stock
FM45-D50-22R-Z05-SN1206	50	60.5	47	22	40	5	3	yes	●
FM45-D63-22R-Z06-SN1206	63	73.5	47	22	40	6	3	yes	●
FM45-D80-27R-Z07-SN1206	80	90.5	58	27	50	7	3	yes	●
FM45-D100-32R-Z08-SN1206	100	110.5	75	32	50	8	3	no	●
FM45-D125-40R-Z09-SN1206	125	135.5	88	40	63	9	3	no	●
FM45-D160-40R-Z12-SN1206	160	170.5	100	40	63	12	3	no	●
FM45-D200-60R-Z14-SN1206	200	210.5	130	60	63	14	3	no	○
FM45-D250-60R-Z16-SN1206	250	260.5	160	60	63	16	3	no	○
FM45-D315-60R-Z20-SN1206	315	325.5	220	60	63	20	3	no	○
FM45-D400-60R-Z28-SN1206	400	410.5	260	60	63	28	3	no	○

Size	Insert	Screw	Wrench
FM45-D50...SN1206...	SN..1206	M5x12	T20



Face Milling Cutter, 45° 平面面铣刀盘, 45°

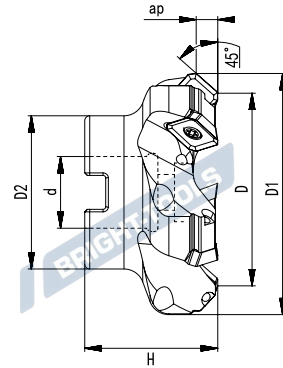

Size	D	D1	D2	d	h	z	ap	Internal Cooling	Stock
FM45-D50-22R-Z04-SE13	50	63	47	22	40	4	6	yes	●
FM45-D63-22R-Z05-SE13	63	76	47	22	40	5	6	yes	●
FM45-D80-27R-Z06-SE13	80	93	58	27	50	6	6	yes	●
FM45-D100-32R-Z07-SE13	100	103	75	32	50	7	6	no	●
FM45-D125-40R-Z08-SE13	125	138	88	40	63	8	6	no	●
FM45-D160-40R-Z10-SE13	160	173	100	40	63	10	6	no	●
FM45-D200-60R-Z12-SE13	200	213	130	60	63	12	6	no	○

Size	Insert	Screw	Wrench
FM45-D50..SE13...	SE..13T3	M3.5x10	T15

Face Milling Cutter, 45° 平面面铣刀盘, 45°

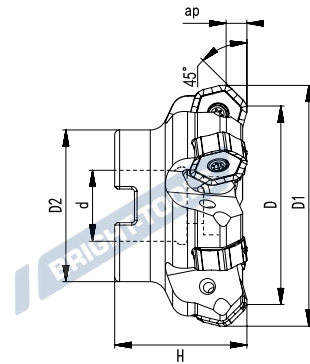

Size	D	D1	D2	d	h	z	ap	Internal Cooling	Stock
FM45-D050-22R-Z4-HN09	50	61	-	22	40	4	4.5	yes	●
FM45-D050-22R-Z5-HN09	50	61	-	22	40	5	4.5	yes	●
FM45-D063-22R-Z4-HN09	63	74	-	22	40	4	4.5	yes	●
FM45-D063-22R-Z6-HN09	63	74	-	22	40	6	4.5	yes	●
FM45-D080-27R-Z5-HN09	80	91	-	27	50	5	4.5	yes	●
FM45-D080-27R-Z6-HN09	80	91	-	27	50	6	4.5	yes	●
FM45-D100-32R-Z6-HN09	100	111	-	32	50	6	4.5	no	○
FM45-D100-32R-Z8-HN09	100	111	-	32	50	8	4.5	no	●
FM45-D125-40R-Z8-HN09	125	136	-	40	63	8	4.5	no	●
FM45-D125-40R-Z10-HN09	125	136	-	40	63	10	4.5	no	●
FM45-D160-40R-Z10-HN09	160	171	-	40	63	10	4.5	no	●
FM45-D160-40R-Z12-HN09	160	171	-	40	63	12	4.5	no	●
FM45-D200-60R-Z16-HN09	200	211	-	60	63	16	4.5	no	●
FM45-D250-60R-Z18-HN09	250	261	-	60	63	18	4.5	no	○
FM45-D315-60R-Z20-HN09	315	326	-	60	63	20	4.5	no	○

Size	Insert	Screw	Wrench
FM45-D050...HN09...	HNMX0906	M4.5x12	T20

Face Milling Cutter, 45° 平面面铣刀盘, 45°

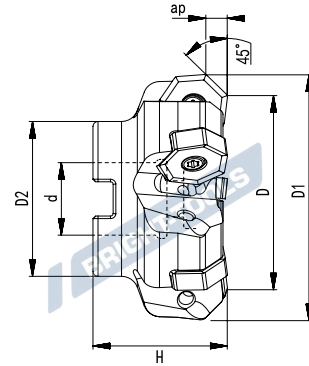

Size	D	D1	D2	d	h	z	ap	Internal Cooling	Stock
FM45-D50-22R-Z04-XN09	50	63	47	22	40	4	4.5	yes	●
FM45-D63-22R-Z05-XN09	63	76	47	22	40	5	4.5	yes	●
FM45-D80-27R-Z06-XN09	80	93	58	27	50	6	4.5	yes	●
FM45-D100-32R-Z07-XN09	100	103	75	32	50	7	4.5	no	●
FM45-D100-32R-Z08-XN09	100	103	75	32	50	8	4.5	no	●
FM45-D125-40R-Z08-XN09	125	138	88	40	63	8	4.5	no	●
FM45-D160-40R-Z09-XN09	160	173	100	40	63	9	4.5	no	●
FM45-D200-60R-Z12-XN09	200	213	130	60	63	12	4.5	no	●

Size	Insert	Screw	Wrench
FM45-D50...XN09...	XNMX0906	M4.5x12	T20

Face Milling Cutter, 75° 平面面铣刀盘, 75°

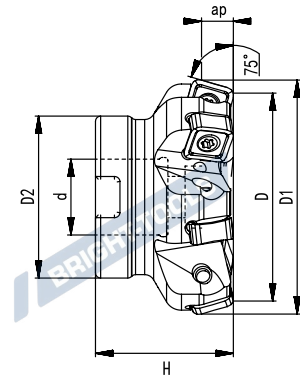

Size	D	D1	D2	d	h	z	ap	Internal Cooling	Stock
FM75-D50-22R-Z05-SN1206	50	60.5	47	22	40	5	5	yes	●
FM75-D63-22R-Z06-SN1206	63	73.5	47	22	40	6	5	yes	●
FM75-D80-27R-Z07-SN1206	80	90.5	58	27	50	7	5	yes	●
FM75-D100-32R-Z08-SN1206	100	110.5	75	32	50	8	5	no	●
FM75-D125-40R-Z09-SN1206	125	135.5	88	40	63	9	5	no	●
FM75-D160-40R-Z12-SN1206	160	170.5	100	40	63	12	5	no	●
FM75-D200-60R-Z14-SN1206	200	210.5	130	60	63	14	5	no	○
FM75-D250-60R-Z16-SN1206	250	260.5	160	60	63	16	5	no	○
FM75-D315-60R-Z20-SN1206	315	325.5	220	60	63	20	5	no	○
FM75-D400-60R-Z28-SN1206	400	410.5	260	60	63	28	5	no	○

Size	Insert	Screw	Wrench
FM75-D50...SN1206...	SN..1206	M5x12	T20

Face Milling Cutter, 90° 平面面铣刀盘, 90°

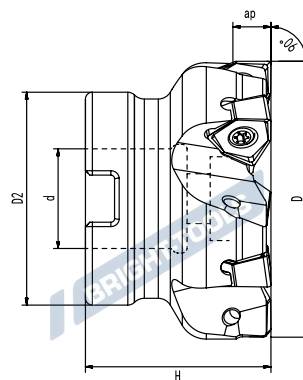

Size	D	D1	D2	d	h	z	ap	Internal Cooling	Stock
FM90-D50-22R-Z04-ZN08	50	-	47	22	40	4	7	yes	●
FM90-D50-22R-Z05-ZN08	50	-	47	22	40	5	7	yes	●
FM90-D63-22R-Z05-ZN08	63	-	47	22	40	5	7	yes	●
FM90-D63-22R-Z06-ZN08	63	-	47	22	40	6	7	yes	●
FM90-D80-27R-Z06-ZN08	80	-	58	27	50	6	7	yes	●
FM90-D80-27R-Z07-ZN08	80	-	58	27	50	7	7	yes	●
FM90-D100-32R-Z08-ZN08	100	-	75	32	50	8	7	no	●
FM90-D125-40R-Z09-ZN08	125	-	88	40	63	9	7	no	○
FM90-D125-40R-Z11-ZN08	125	-	88	40	63	11	7	no	○
FM90-D160-40R-Z10-ZN08	160	-	100	40	63	10	7	no	○
FM90-D200-60R-Z12-ZN08	200	-	130	60	63	12	7	no	○

Size	Insert	Screw	Wrench
FM90-D50...ZN08...	ZN..0806	M4X10	T15

BRIGHT-TOOLS

BRIGHT-TOOLS

BRIGHT-TOOLS

BRIGHT-TOOLS

Face Milling Cutter, 90° 平面面铣刀盘, 90°

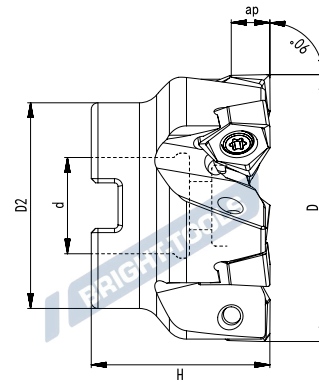

Size	D	D1	D2	d	h	z	ap	Internal Cooling	Stock
FM90-D50-22R-Z04-WN08	50	-	47	22	40	4	7.5	yes	●
FM90-D50-22R-Z05-WN08	50	-	47	22	40	5	7.5	yes	●
FM90-D63-22R-Z05-WN08	63	-	47	27	40	5	7.5	yes	●
FM90-D63-22R-Z06-WN08	63	-	47	32	40	6	7.5	yes	●
FM90-D80-27R-Z06-WN08	80	-	58	40	50	6	7.5	yes	●
FM90-D80-27R-Z07-WN08	80	-	58	40	50	7	7.5	yes	●
FM90-D100-32R-Z08-WN08	100	-	75	32	50	8	7.5	no	●
FM90-D125-40R-Z09-WN08	125	-	88	40	63	9	7.5	no	○
FM90-D125-40R-Z11-WN08	125	-	88	40	63	11	7.5	no	○
FM90-D160-40R-Z10-WN08	160	-	100	40	63	10	7.5	no	○
FM90-D200-40R-Z12-WN08	200	-	130	60	63	12	7.5	no	○

Size	Insert	Screw	Wrench
FM90-D50...WN08...	WN..0806	M5X12	T20



Face Milling Cutter, Round Inserts 仿形面铣刀盘

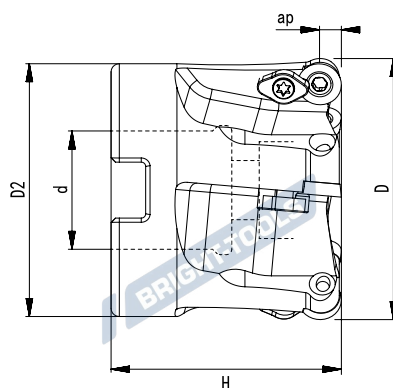

Size	D	D1	D2	d	h	z	ap	Internal Cooling	Stock
RP08-D40-16R-4T	50	-	47	22	40	4	4	no	●
RP08-D50-22R-5T	50	-	47	22	42	5	4	no	●
RP08-D63-22R-6T	63	-	47	22	42	4	4	no	●

Size	Clamp	Clamp screw	Insert	Insert Screw	Wrench
RP08-D40...4T...	A-4R	M3X7	RP..0802	M3X7	T10

Face Milling Cutter, Round Inserts 仿形面铣刀盘

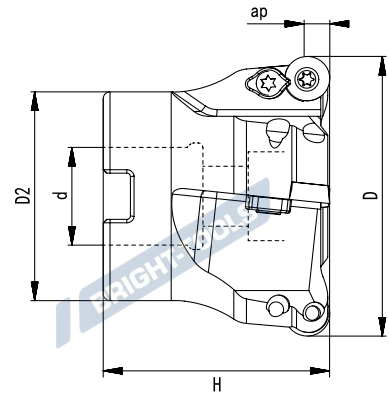

Size	D	D1	D2	d	h	z	ap	Internal Cooling	Stock
RP10-D50-22R-4T	63	-	47	22	50	5	5	no	●
RP10-D63-22R-4T	80	-	58	27	50	6	5	no	●
RP10-D63-22R-5T	100	-	75	32	50	7	5	no	●
RP10-D80-27R-6T	125	-	88	40	50	8	5	no	●
RP10-D100-32R-6T	160	-	110	40	50	9	5	no	●

Size	Clamp	Clamp screw	Insert	Insert Screw	Wrench
RP10-D50...4T...	A-5R	M3.5X9	RP..1003/RD..1003	M4X9	T15



Face Milling Cutter, Round Inserts

仿形面铣刀盘

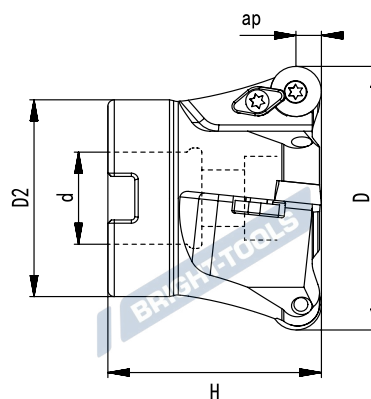

Size	D	D1	D2	d	h	z	ap	Internal Cooling	Stock
RP12-D50-22R-4T	50	-	47	22	50	4	6	no	●
RP12-D63-22R-4T	63	-	47	22	50	4	6	no	●
RP12-D63-22R-5T	63	-	47	22	50	5	6	no	●
RP12-D80-27R-6T	80	-	58	27	50	6	6	no	●
RP12-D100-32R-6T	100	-	75	32	50	6	6	no	●
RP12-D125-40R-8T	125	-	88	40	63	8	6	no	●
RP12-D160-40R-9T	160	-	110	40	63	9	6	no	●
RP12-D200-60R-10T	200	-	130	60	63	10	6	no	○

Size	Clamp	Clamp screw	Insert	Insert Screw	Wrench
RP12-D50...4T...	A-6R	M4X9	RP..1204/RD..1204	M4X10	T15

Face Milling Cutter, AMPT Inserts 方肩面铣刀盘

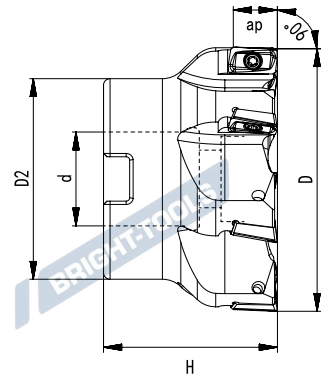

Size	D	D1	D2	d	h	z	ap	Internal Cooling	Stock
BAP300R-D50-22R-6T	50	-	47	22	40	6	14	no	●
BAP300R-D63-22R-7T	63	-	47	22	40	7	14	no	●
BAP300R-D80-27R-8T	80	-	58	27	50	8	14	no	●

Size	Insert	Screw	Wrench
BAP300R-D50...6T...	APMT 1135	M2.5X6	T08

Face Milling Cutter, AMPT Inserts

方肩面铣刀盘

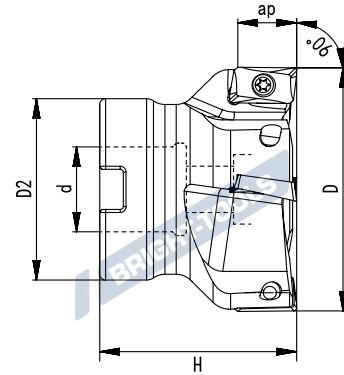

Size	D	D1	D2	d	h	z	ap	Internal Cooling	Stock
BAP400R-D50-22R-4T	50	-	47	22	50	4	14	no	●
BAP400R-D50-22R-5T	50	-	47	22	50	5	14	no	●
BAP400R-D63-22R-4T	63	-	47	22	50	4	14	no	●
BAP400R-D63-22R-5T	63	-	47	22	50	5	14	no	●
BAP400R-D80-27R-6T	80	-	58	27	50	6	14	no	●
BAP400R-D100-32R-7T	100	-	75	32	50	7	14	no	●
BAP400R-D125-40R-8T	125	-	88	40	63	8	14	no	●
BAP400R-D160-40R-9T	160	-	110	40	63	9	14	no	○
BAP400R-D200-60R-9T	200	-	130	60	63	9	14	no	○
BAP400R-D200-60R-12T	200	-	130	60	63	12	14	no	○

Size	Insert	Screw	Wrench
BAP400R-D50...4T...	APMT 1604	M4X10	T15

BRIGHT-TOOLS

BRIGHT-TOOLS

BRIGHT-TOOLS

BRIGHT-TOOLS

High-feed Face Milling Cutter

快进给铣刀盘

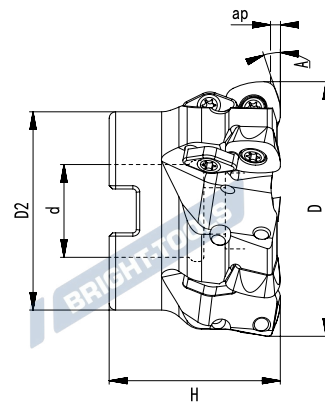
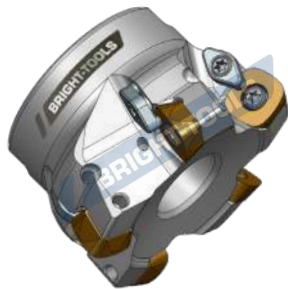

Size	D	D1	D2	d	h	z	ap	Internal Cooling	Stock
FMSD12-D50-22R-Z4-A	50	-	47	22	40	4	2	yes	●
FMSD12-D63-22R-Z5-A	63	-	47	22	40	5	2	yes	●
FMSD12-D80-27R-Z6-A	80	-	58	27	50	6	2	yes	●

Size	Clamp	Clamp screw	Insert	Insert Screw	Wrench
FMSD12-D50...A...	A-6R	M4X10	SD..1205	M4X10	T15



High-feed Face Milling Cutter

快进给铣刀盘

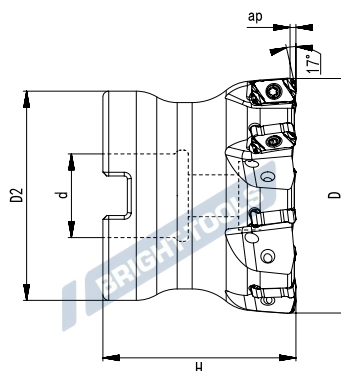

Size	D	D1	D2	d	h	z	ap	Internal Cooling	Stock
FMLN03-D40-16R-Z6	40	-	35	16	40	6	1	yes	●
FMLN03-D50-22R-Z7	50	-	47	22	50	7	1	yes	●
FMLN03-D63-22R-Z8	63	-	55	22	50	8	1	yes	●
FMLN03-D80-27R-Z9	80	-	70	27	50	9	1	yes	●

Size	Insert	Screw	Wrench
FMLN03-D40...Z6...	LN..0303	M2.5X7	T08

BRIGHT-TOOLS

BRIGHT-TOOLS

CUTTING TOOLS

END MILLING

BRIGHT-TOOLS

BRIGHT-TOOLS

BRIGHT-TOOLS

BRIGHT-TOOLS

BRIGHT-TOOLS

BRIGHT-TOOLS

End Milling Cutter, Round Inserts

仿形立铣刀杆

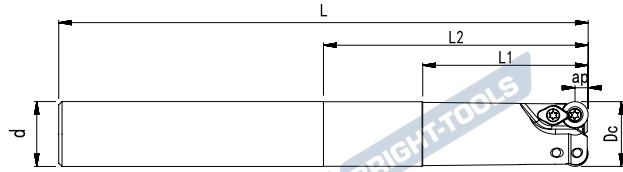
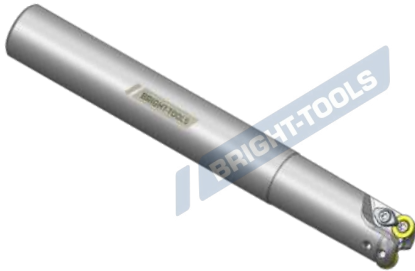

Size	Dc	d	L	L1	L2	z	ap	Internal Cooling	Stock
RP08-D12-120-C12-1T	12	12	120	40	-	1	4	no	●
RP08-D13-120-C12-1T	13	12	120	40	-	1	4	no	●
RP08-D16-120-C12-2T	16	12	120	40	-	2	4	no	●
RP08-D16-160-C16-2T	16	16	160	40	-	2	4	no	●
RP08-D16-200-C16-2T	16	16	200	40	100	2	4	no	●
RP08-D17-160-C16-2T	17	16	160	40	-	2	4	no	●
RP08-D17-200-C16-2T	17	16	200	40	-	2	4	no	●
RP08-D20-160-C20-2T	20	20	160	50	-	2	4	no	●
RP08-D20-200-C20-2T	20	20	200	50	100	2	4	no	●
RP08-D21-160-C20-2T	21	20	160	50	-	2	4	no	●
RP08-D21-200-C20-2T	21	20	200	50	-	2	4	no	●

Size	Clamp	Clamp screw	Insert	Insert Screw	Wrench
RP08-D12...1T...	A-4R	M3X7	RP..0802	M3X7	T08

End Milling Cutter, Round Inserts 仿形立铣刀杆

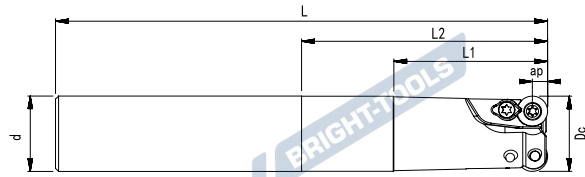

Size	Dc	d	L	L1	L2	z	ap	Internal Cooling	Stock
RP10-D20-160-C20-2T	20	20	160	50	-	2	5	no	●
RP10-D20-200-C20-2T	20	20	200	50	-	2	5	no	●
RP10-D21-160-C20-2T	21	20	160	50	-	2	5	no	●
RP10-D25-160-C25-2T	25	25	160	50	-	2	5	no	●
RP10-D25-160-C20-2T	25	20	160	50	-	2	5	no	●
RP10-D25-200-C25-2T	25	25	200	75	-	2	5	no	●
RP10-D25-250-C25-2T	25	25	250	70	115	2	5	no	●
RP10-D25-200-C20-2T	25	20	200	50	-	2	5	no	●
RP10-D30-110-C25-2T	30	25	110	40	-	2	5	no	●
RP10-D30-160-C25-2T	30	25	160	50	-	2	5	no	●
RP10-D30-200-C25-2T	30	25	200	60	-	2	5	no	●
RP10-D30-250-C25-2T	30	25	250	60	-	2	5	no	●
RP10-D30-300-C25-2T	30	25	300	60	-	2	5	no	●
RP10-D35-160-C32-3T	35	32	160	50	-	3	5	no	●
RP10-D35-200-C32-3T	35	32	200	50	-	3	5	no	●
RP10-D35-250-C32-3T	35	32	250	60	-	3	5	no	●
RP10-D35-300-C32-3T	35	32	300	60	-	3	5	no	●
RP10-D35-350-C32-3T	35	32	350	60	-	3	5	no	●
RP10-D40-160-C32-3T	40	32	160	50	-	3	5	no	●
RP10-D40-160-C32-4T	40	32	160	50	-	4	5	no	●
RP10-D40-200-C32-4T	40	32	200	50	-	4	5	no	●

Size	 Clamp	 Clamp screw	 Insert	 Insert Screw	 Wrench
RP10-D20...2T...	A-5R	M3.5X9	RP..1003	M4X10	T15

End Milling Cutter, Round Inserts

仿形立铣刀杆

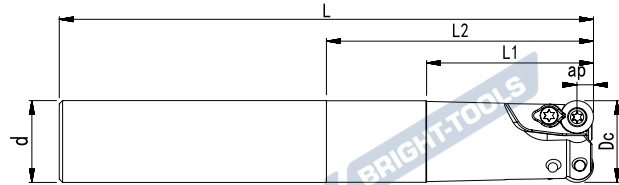

Size	Dc	d	L	L1	L2	z	ap	Internal Cooling	Stock
TRS5R-D20-160-C20-2T	20	20	160	50	-	2	5	no	•
TRS5R-D20-200-C20-2T	20	20	200	50	-	2	5	no	•
TRS5R-D21-160-C20-2T	21	20	160	50	-	2	5	no	•
TRS5R-D25-160-C25-2T	25	25	160	50	-	2	5	no	•
TRS5R-D25-160-C20-2T	25	20	160	50	-	2	5	no	•
TRS5R-D25-200-C25-2T	25	25	200	75	-	2	5	no	•
TRS5R-D25-250-C25-2T	25	25	250	70	115	2	5	no	•
TRS5R-D25-200-C20-2T	25	20	200	50	-	2	5	no	•
TRS5R-D30-110-C25-2T	30	25	110	40	-	2	5	no	•
TRS5R-D30-160-C25-2T	30	25	160	50	-	2	5	no	•
TRS5R-D30-200-C25-2T	30	25	200	60	-	2	5	no	•
TRS5R-D30-250-C25-2T	30	25	250	60	-	2	5	no	•
TRS5R-D30-300-C25-2T	30	25	300	60	-	2	5	no	•
TRS5R-D35-160-C32-3T	35	32	160	50	-	3	5	no	•
TRS5R-D35-200-C32-3T	35	32	200	50	-	3	5	no	•
TRS5R-D35-250-C32-3T	35	32	250	60	-	3	5	no	•
TRS5R-D35-300-C32-3T	35	32	300	60	-	3	5	no	•
TRS5R-D35-350-C32-3T	35	32	350	60	-	3	5	no	•
TRS5R-D40-160-C32-3T	40	32	160	50	-	3	5	no	•
TRS5R-D40-160-C32-4T	40	32	160	50	-	4	5	no	•
TRS5R-D40-200-C32-4T	40	32	200	50	-	4	5	no	•



Size	Clamp	Clamp screw	Insert	Insert Screw	Wrench
TRS5R-D20...2T...	A-5R	M3.5X9	RD..10T3	M4X10	T15

End Milling Cutter, Round Inserts 仿形立铣刀杆

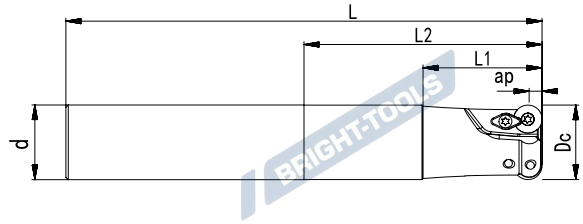

Size	Dc	d	L	L1	L2	z	ap	Internal Cooling	Stock
RP12-D32-160-C25-2T	32	25	160	50	-	2	6	no	●
RP12-D32-160-C32-2T	32	32	160	50	-	2	6	no	●
RP12-D32-200-C25-2T	32	25	200	60	-	2	6	no	●
RP12-D32-200-C32-2T	32	32	200	80	-	2	6	no	●
RP12-D35-160-C32-3T	35	32	160	50	-	3	6	no	●
RP12-D35-200-C32-3T	35	32	200	60	-	3	6	no	●
RP12-D35-250-C32-3T	35	32	250	60	-	3	6	no	●
RP12-D35-300-C32-3T	35	32	300	60	-	3	6	no	●
RP12-D35-350-C32-3T	35	32	350	50	-	3	6	no	●
RP12-D40-160-C32-3T	40	32	160	50	-	3	6	no	●
RP12-D40-200-C32-3T	40	32	200	60	-	3	6	no	●
RP12-D40-250-C32-3T	40	32	250	60	-	3	6	no	●

Size	Clamp	Clamp screw	Insert	Insert Screw	Wrench
RP12-D32...2T...	A-6R	M4X10	RP..1204	M4X10	T15

End Milling Cutter, AMPT Inserts

方肩立铣刀杆

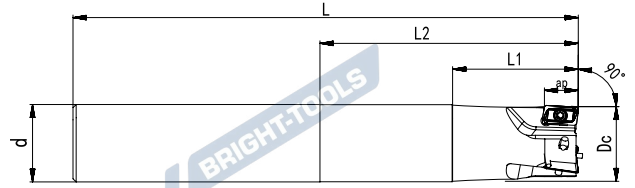

Size	Dc	d	L	L1	L2	z	ap	Internal Cooling	Stock
BAP300R-D10-120-C10-1T	10	10	120	30	-	1	9	no	●
BAP300R-D12-100-C12-1T	12	12	100	30	-	1	9	no	●
BAP300R-D12-120-C12-1T	12	12	120	30	-	1	9	no	●
BAP300R-D12-130-C12-1T	12	12	130	30	-	1	9	no	●
BAP300R-D12-150-C12-1T	12	12	150	40	-	1	9	no	●
BAP300R-D13-120-C12-1T	13	12	120	30	-	1	9	no	●
BAP300R-D13-130-C12-1T	13	12	130	40	-	1	9	no	●
BAP300R-D13-150-C12-1T	13	12	150	40	-	1	9	no	●
BAP300R-D16-120-C16-2T	16	16	120	40	-	2	9	no	●
BAP300R-D16-160-C16-2T	16	16	160	40	-	2	9	no	●
BAP300R-D16-180-C15-2T	16	15	180	40	-	2	9	no	●
BAP300R-D16-180-C16-2T	16	16	180	40	-	2	9	no	●
BAP300R-D16-200-C16-2T	16	16	200	40	100	2	9	no	●
BAP300R-D17-160-C16-2T	17	16	160	40	-	2	9	no	●
BAP300R-D17-180-C16-2T	17	16	180	40	-	2	9	no	●
BAP300R-D17-200-C16-2T	17	16	200	40	-	2	9	no	●
BAP300R-D20-120-C20-3T	20	20	120	40	-	3	9	no	●
BAP300R-D20-160-C20-3T	20	20	160	50	-	3	9	no	●
BAP300R-D20-180-C20-2T	20	20	180	50	-	2	9	no	●
BAP300R-D20-200-C20-2T	20	20	200	50	100	2	9	no	●
BAP300R-D21-150-C20-2T	21	20	150	40	-	2	9	no	●
BAP300R-D21-160-C20-2T	21	20	160	40	-	2	9	no	●
BAP300R-D21-200-C20-2T	21	20	200	50	-	2	9	no	●
BAP300R-D25-160-C25-3T	25	25	160	50	-	3	9	no	●
BAP300R-D25-200-C25-3T	25	25	200	75	-	3	9	no	●
BAP300R-D30-160-C25-3T	30	25	160	50	-	3	9	no	●

Size	Insert	Screw	Wrench
BAP300R-D10..1T...	APMT1135PDER	M2.5X5	T08
BAP300R-D16..2T...	APMT1135PDER	M2.5X6	T08

End Milling Cutter, AMPT Inserts 方肩立铣刀杆

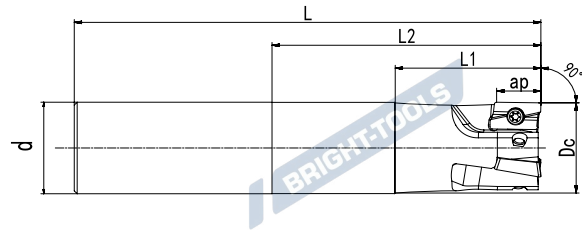

Size	Dc	d	L	L1	L2	z	ap	Internal Cooling	Stock
BAP400R-D20-160-C20-2T	20	20	160	50	-	2	14	no	●
BAP400R-D20-200-C20-2T	20	20	200	50	-	2	14	no	●
BAP400R-D25-160-C24-2T	25	24	160	50	-	2	14	no	●
BAP400R-D25-160-C25-2T	25	25	160	50	-	2	14	no	●
BAP400R-D25-200-C24-2T	25	24	200	75	-	2	14	no	●
BAP400R-D25-200-C25-2T	25	25	200	75	-	2	14	no	●
BAP400R-D25-250-C24-2T	25	24	250	50	-	2	14	no	●
BAP400R-D25-250-C25-2T	25	25	250	50	115	2	14	no	●
BAP400R-D26-160-C25-2T	26	25	160	50	-	2	14	no	●
BAP400R-D26-200-C25-2T	26	25	200	50	-	2	14	no	●
BAP400R-D32-160-C25-3T	32	25	160	50	-	3	14	no	●
BAP400R-D32-200-C25-2T	32	25	200	50	-	2	14	no	●
BAP400R-D32-200-C25-3T	32	25	200	50	-	3	14	no	●
BAP400R-D32-160-C32-3T	32	32	160	80	-	3	14	no	●
BAP400R-D32-200-C32-3T	32	32	200	80	-	3	14	no	●
BAP400R-D32-250-C32-3T	32	32	250	80	-	3	14	no	●
BAP400R-D35-160-C32-3T	35	32	160	50	-	3	14	no	●
BAP400R-D35-200-C32-3T	35	32	200	50	-	3	14	no	●
BAP400R-D35-250-C32-3T	35	32	250	60	-	3	14	no	●
BAP400R-D40-160-C32-3T	40	32	160	50	-	3	14	no	●
BAP400R-D40-200-C32-3T	40	32	200	50	-	3	14	no	●
BAP400R-D40-250-C32-3T	40	32	250	60	-	3	14	no	●

Size	Insert	Screw	Wrench
BAP400R-D20...2T...	APMT 1604PDER	M4X8	T15
BAP400R-D25...2T...	APMT 1604PDER	M4X9	T15

High-feed End Milling Cutter

快进给铣刀杆

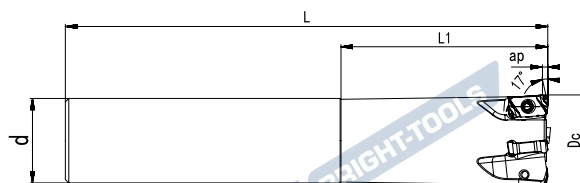

Size	Dc	d	L	L1	L2	z	ap	Internal Cooling	Stock
EXN03-D16-C16-100-02	16	16	100	30	-	2	1	no	●
EXN03-D16-C16-150-02	16	16	150	50	-	2	1	no	●
EXN03-D18-C16-100-02	18	16	100	30	-	2	1	no	●
EXN03-D18-C16-150-02	18	16	150	25	-	2	1	no	●
EXN03-D20-C20-130-03	20	20	130	50	-	3	1	no	●
EXN03-D20-C20-160-03	20	20	160	80	-	3	1	no	●
EXN03-D22-C20-130-03	22	20	130	50	-	3	1	no	●
EXN03-D22-C20-160-03	22	20	160	30	-	3	1	no	●
EXN03-D25-C25-140-04	25	25	140	60	-	4	1	no	●
EXN03-D25-C25-180-04	25	25	180	100	-	4	1	no	●
EXN03-D26-C25-140-04	26	25	140	60	-	4	1	no	●
EXN03-D26-C25-180-04	26	25	180	60	-	4	1	no	●
EXN03-D28-C25-140-04	28	25	140	60	-	4	1	no	●
EXN03-D28-C25-180-04	28	25	180	35	-	4	1	no	●
EXN03-D30-C32-150-05	30	32	150	70	-	5	1	no	●
EXN03-D30-C32-200-05	30	32	200	120	-	5	1	no	●
EXN03-D32-C32-150-05	32	32	150	70	-	5	1	no	●
EXN03-D32-C32-200-05	32	32	200	120	-	5	1	no	●
EXN03-D35-C32-150-05	35	32	150	35	-	5	1	no	●
EXN03-D35-C32-200-05	35	32	200	35	-	5	1	no	●
EXN03-D40-C32-150-06	40	32	150	45	-	6	1	no	●
EXN03-D40-C32-220-06	40	32	220	45	-	6	1	no	●



Size	Insert	Screw	Wrench
EXN03-D16...02...	LN..0303	M2.5X7XD3.6	T08

BRIGHT-TOOLS

BRIGHT-TOOLS

CUTTING TOOLS

SCREW-IN MILLING

BRIGHT-TOOLS

BRIGHT-TOOLS

BRIGHT-TOOLS

BRIGHT-TOOLS

BRIGHT-TOOLS

BRIGHT-TOOLS

Screw-in Milling Cutter, Round Inserts

仿形锁牙式铣刀

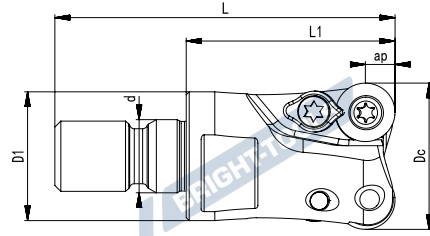
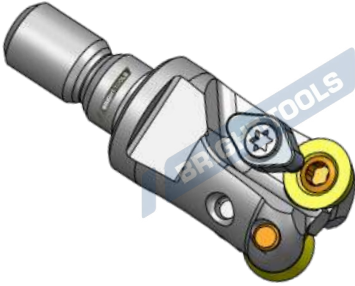

Size	Dc	d	D1	L	L1	z	ap	Stock
RP08-D16-M8-2T	16	8.5	14.5	42	25	2	4	●
RP08-D17-M8-2T	17	8.5	14.5	42	25	2	4	●
RP08-D20-M10-2T	20	10.5	18	49	30	2	4	●
RP08-D21-M10-2T	21	10.5	18	49	30	2	4	●
RP08-D25-M12-3T	25	12.5	22	57	35	3	4	●
RP08-D26-M12-3T	26	12.5	22	57	35	3	4	●

Size	Clamp	Clamp screw	Insert	Insert Screw	Wrench
RP08-D16...2T...	A-4R	M3X7	RP..0802	M3X7	T10

Screw-in Milling Cutter, Round Inserts 仿形锁牙式铣刀

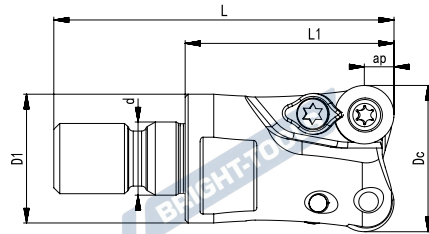
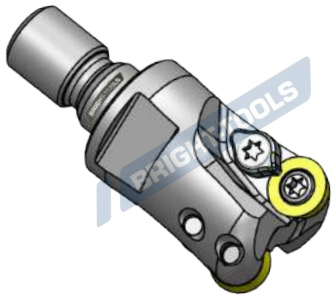

Size	Dc	d	D1	L	L1	z	ap	Stock
RP10-D20-M10-2T	20	10.5	18	49	30	2	5	•
RP10-D21-M10-2T	21	10.5	18	49	30	2	5	•
RP10-D25-M12-2T	25	12.5	22	57	35	2	5	•
RP10-D30-M16-2T	30	17	29	63	40	2	5	•

Size	Clamp	Clamp Screw	Insert Screw	Screw	Wrench
RP10-D20...2T...	A-5R	M3.5X9	RP..1003	M4X9	T15



Screw-in Milling Cutter, Round Inserts

仿形锁牙式铣刀

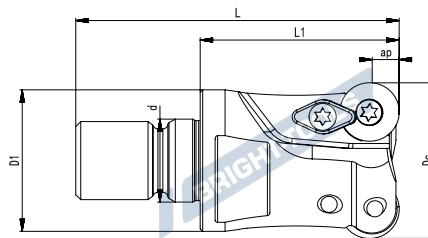
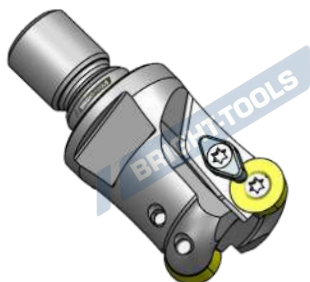

Size	Dc	d	D1	L	L1	z	ap	Stock
RP12-D32-M16-2T	32	17	29	63	40	2	6	●
RP12-D35-M16-3T	35	17	29	63	40	3	6	●

Size	Clamp	Clamp Screw	Insert	Insert Screw	Wrench
RP12-D32...2T...	A-6R	M4X9	RP..1204	M4X10	T15

Screw-in Milling Cutter, AMPT Inserts 方肩锁牙式铣刀

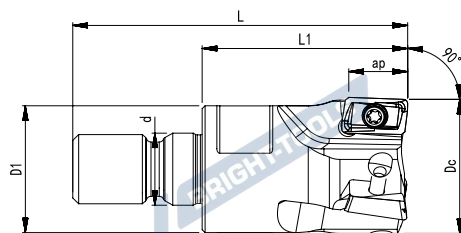

Size	Dc	d	D1	L	L1	z	ap	Stock
BAP300R-D16-M8-2T	16	8.5	14.5	42	25	2	9	●
BAP300R-D17-M8-2T	17	8.5	14.5	42	25	2	9	●
BAP300R-D20-M10-2T	20	10.5	18	49	30	2	9	●
BAP300R-D21-M10-2T	21	10.5	18	49	30	2	9	●
BAP300R-D25-M12-3T	25	12.5	22	57	35	3	9	●
BAP300R-D30-M16-3T	30	17	29	63	40	3	9	●

Size	Insert	Screw	Wrench
BAP300R-D16...2T...	APMT 1135PDER	M2.5X6	T08

Screw-in Milling Cutter, AMPT Inserts

方肩锁牙式铣刀

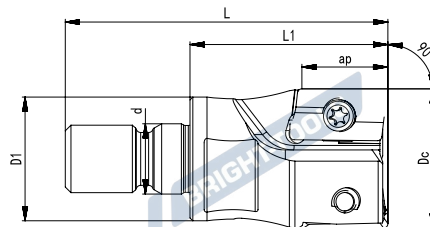
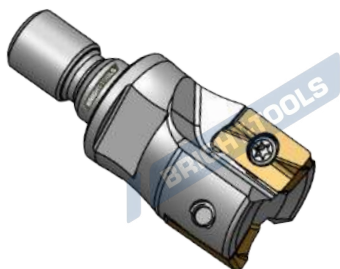

Size	Dc	d	D1	L	L1	z	ap	Stock
BAP400R-D25-M12-2T	25	12.5	22	57	35	2	14	●
BAP400R-D26-M12-2T	26	12.5	22	57	35	2	14	●
BAP400R-D32-M16-3T	32	17	29	63	40	3	14	●

Size	Insert	Screw	Wrench
BAP400R-D25...2T...	APMT 1604PDER	M4X9	T15

High-feed Screw-in Milling Cutter 快进给锁牙式铣刀

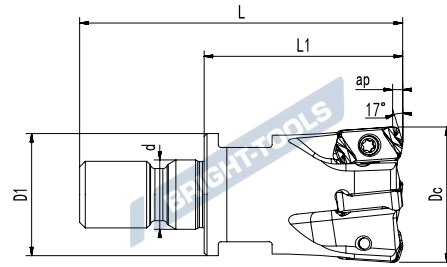
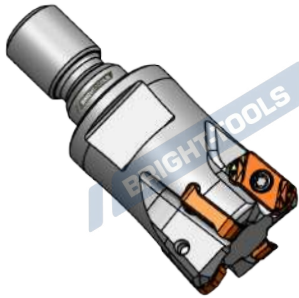

Size	Dc	d	D1	L	L1	z	ap	Stock
EXN03-D16-M10-02	16	8.5	14.5	42	25	2	1	●
EXN03-D20-M10-03	20	10.5	18	49	30	3	1	●
EXN03-D22-M10-03	22	10.5	18	49	30	3	1	●
EXN03-D25-M12-04	25	12.5	22	57	35	4	1	●
EXN03-D32-M16-05	32	17	29	63	40	5	1	●

Size	Insert	Screw	Wrench
EXN03-D16...02...	LN..0303	M2.5X7	T08

BRIGHT-TOOLS

BRIGHT-TOOLS

CUTTING TOOLS

INSERTS

BRIGHT-TOOLS

BRIGHT-TOOLS

BRIGHT-TOOLS

BRIGHT-TOOLS

BRIGHT-TOOLS

BRIGHT-TOOLS

SE Inserts

SE 单面正型 4 刃刀片

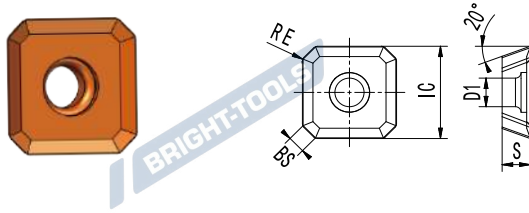

P: 钢 M: 不锈钢 K: 铸铁 S: 有色金属 N: 耐热合金、钛合金

● Stable Cut ○ Normal Cut ○ Unstable Cut
● 稳定切削 ○ 一般切削 ○ 不稳定切削

	P	M	K	S	N
BT6130	●	○	●	○	○
BT8140	○	○	○	○	○
BT5110	○	○	○	○	○
BT5210	○	○	○	○	○
BT5120	○	○	○	○	○
BT5220	○	○	○	○	○
BT5130	○	○	○	○	○
BT530	○	○	○	○	○
BT7130	○	○	○	○	○
BT7140	○	○	○	○	○
BT7240	○	○	○	○	○
BTK10	○	○	○	○	○
BTC10	○	○	○	○	○

Tough ↔ Hard

Size	IC	S	D1	BS	RE	APMX	BT6130	BT8140	BT5110	BT5210	BT5120	BT5220	BT5130	BT530	BT7130	BT7140	BT7240	BTK10	BTC10
SEET13T3-GM	13.4	3.97	4.1	1.4	1.5	6	★	☆	☆	★	★	★							
SEMT13T3AGTN-FM	13.4	3.97	4.1	1.4	1.5	6	★	☆	☆	★	★	★							

★ Rec Size ☆ Opt Size
★ 主推型号 ☆ 可选型号

HN Inserts

HN 双面负型 12 刃刀片

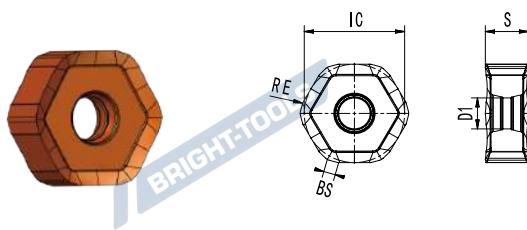

P: 钢 M: 不锈钢 K: 铸铁 S: 有色金属 N: 耐热合金、钛合金

● Stable Cut ○ Normal Cut ○ Unstable Cut
● 稳定切削 ○ 一般切削 ○ 不稳定切削

	P	M	K	S	N
BT6130	●	○	○	○	○
BT8140	○	○	○	○	○
BT5110	○	○	○	○	○
BT5210	○	○	○	○	○
BT5120	○	○	○	○	○
BT5220	○	○	○	○	○
BT5130	○	○	○	○	○
BT530	○	○	○	○	○
BT7130	○	○	○	○	○
BT7140	○	○	○	○	○
BT7240	○	○	○	○	○
BTK10	○	○	○	○	○
BTC10	○	○	○	○	○

Tough ↔ Hard

Size	IC	S	D1	BS	RE	APMX	BT6130	BT8140	BT5110	BT5210	BT5120	BT5220	BT5130	BT530	BT7130	BT7140	BT7240	BTK10	BTC10
HNMX0906ANSN-M	16.5	6.34	4.9	1.0	1.2	5	★	☆	☆	★	★	★							

★ Rec Size ☆ Opt Size
★ 主推型号 ☆ 可选型号

WN Inserts

WN 负型 6 刃刀片

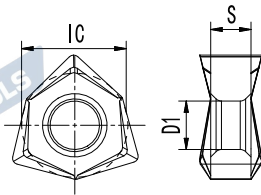

P: 钢 M: 不锈钢 K: 铸铁 S: 有色金属 N: 耐热合金、钛合金

Size	IC	S	D1	BS	RE	Tough ↔ Hard															
						BT6130	BT8140	BT5110	BT5210	BT5120	BT5220	BT5130	BT530	BT7130	BT7140	BT7240	BTK10	BTC10			
WNEU080608EN-GL	14.02	6.65	6.2	1.5	0.8	☆		☆	★	★	★	★	☆								
WNMU080608EM-GM	14.02	6.65	6.2	1.3	0.8	☆	☆	★	★	★	★	★	☆								

★ Rec Size ☆ Opt Size
★ 主推型号 ☆ 可选型号

● Stable Cut ◎ Normal Cut ○ Unstable Cut
● 稳定切削 ◎ 一般切削 ○ 不稳定切削

P	○	○	●	●	◎	◎	○	◎	○	○	○	○	○	○	○	○	○	○	○	○	○
M			●	●	◎	◎	○	◎													
K	○	○	●	●	◎	◎	○	◎													
S																				◎	
N																					

RD Inserts

RD 圆形刀片

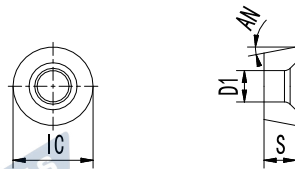

P: 钢 M: 不锈钢 K: 铸铁 S: 有色金属 N: 耐热合金、钛合金

Size	IC	S	D1	AN	APMX	Tough ↔ Hard															
						BT6130	BT8140	BT5110	BT5210	BT5120	BT5220	BT5130	BT530	BT7130	BT7140	BT7240	BTK10	BTC10			
RDMW0602MO	6	2.38	2.5	15°	3	☆		☆	★	★	★	★	☆								
RDMW0802MO	8	2.38	3.4	15°	4	☆		☆	★	★	★	★	☆								
RDMW10T3MO	10	3.97	4.5	15°	5	☆		☆	★	★	★	★	☆								
RDMW1204MO	12	4.76	5.5	15°	6	☆		☆	★	★	★	★	☆								
RDMW1605MO	16	5.56	5.5	15°	8	☆		☆	★	★	★	★	☆								
RDKW10T3MO	10	3.97	4.5	15°	5	☆		☆	★	★	★	★	☆								
RDKW1204MO	12	4.76	4.4	15°	6	☆		☆	★	★	★	★	☆								
RDKW1604MO	16	4.76	5.5	15°	8	☆		☆	★	★	★	★	☆								

★ Rec Size ☆ Opt Size
★ 主推型号 ☆ 可选型号

● Stable Cut ◎ Normal Cut ○ Unstable Cut
● 稳定切削 ◎ 一般切削 ○ 不稳定切削

P	○	○	●	●	◎	◎	○	◎	○	○	○	○	○	○	○	○	○	○	○	○	○
M			●	●	◎	◎	○	◎													
K	○	○	●	●	◎	◎	○	◎													
S																				◎	
N																					

RP Inserts RP 圆形刀片

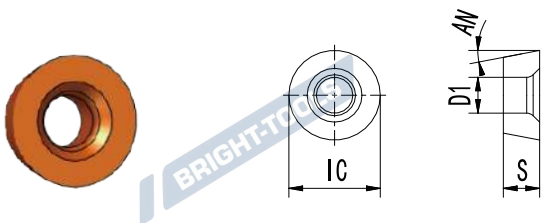

P: 钢 M: 不锈钢 K: 铸铁 S: 有色金属 N: 耐热合金、钛合金

Size	IC	S	D1	AN	APMX	Tough ↔ Hard															
						BT6130	BT8140	BT5110	BT5210	BT5120	BT5220	BT5130	BT530	BT7130	BT7140	BT7240	BTK10	BTC10			
RPMT08T2MO-HM	8.0	2.78	3.4	11°	4	☆		☆	★	★	★	★	☆								
RPMW1003MO	10.0	3.18	4.5	11°	5	☆		☆	★	★	★	★	☆								
RPMT1204MO-HM	12.0	4.76	4.4	11°	6	☆		☆	★	★	★	★	☆								

★ Rec Size ☆ Opt Size
★ 主推型号 ☆ 可选型号

● Stable Cut ◎ Normal Cut ○ Unstable Cut
● 稳定切削 ◎ 一般切削 ○ 不稳定切削

P	○	○	●	●	◎	◎	○	◎	○	○	○	○	○	○	○	○	○	○	○	○	○
M			●	●	◎	◎	○	◎													
K	○	○	●	●	◎	◎	○	◎													
S																					◎
N																					

RP Inserts RP 圆形刀片

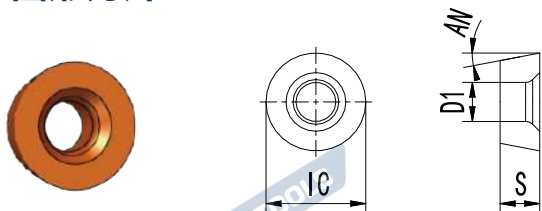

P: 钢 M: 不锈钢 K: 铸铁 S: 有色金属 N: 耐热合金、钛合金

Size	IC	S	D1	AN	APMX	Tough ↔ Hard																	
						BT6130	BT8140	BT5110	BT5210	BT5120	BT5220	BT5130	BT530	BT7130	BT7140	BT7240	BTK10	BTC10					
RPKT10T3MO-MS	10	3.97	3.4	11°	5																★	★	
RPKT1204MO-MS	12	4.76	4.4	11°	6																	★	★
RPKT1606MO-MS	16	6.35	5.5	11°	8		★															★	★
RPMT08T2MO-SM	8	2.78	3.4	11°	4																	★	★
RPMT10T3MO-SM	10	3.97	4.4	11°	5																	★	★
RPMT1204MO-SM	12	4.76	4.4	11°	6																	★	★
RPMT1606MO-SM	16	6.35	5.5	11°	8		★															★	★

★ Rec Size ☆ Opt Size
★ 主推型号 ☆ 可选型号

● Stable Cut ◎ Normal Cut ○ Unstable Cut
● 稳定切削 ◎ 一般切削 ○ 不稳定切削

P	○	○	●	●	◎	◎	○	◎	○	○	○	○	○	○	○	○	○	○	○	○	○
M			●	●	◎	◎	○	◎													
K	○	○	●	●	◎	◎	○	◎													
S																					◎
N																					

LN Inserts

LN 负型 4 刃刀片

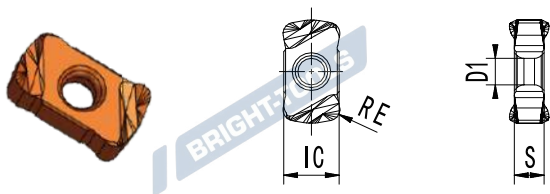

● Stable Cut ⊙ Normal Cut ○ Unstable Cut
● 稳定切削 ⊙ 一般切削 ○ 不稳定切削

P	○	○	●	●	⊙	⊙	○	○	○	○	○	○	○	○	○
M			●	●	⊙	⊙	○	○	○	○	○	○	○	○	○
K	○	○	●	●	⊙	⊙	○	○	○	○	○	○	○	○	○
S														⊙	
N															

P: 钢 M: 不锈钢 K: 铸铁 S: 有色金属 N: 耐热合金、钛合金

Size	IC	S	D1	AN	RE	APMX	Tough ↔ Hard														
							BT6130	BT8140	BT5110	BT5210	BT5120	BT5220	BT5130	BT530	BT7130	BT7140	BT7240	BTk10	BTC10		
LNKU0303ZNR-MH	6	3.67	3	0°	1.2	1.3	☆		☆	☆	★	★	★	★							
LNKU0303ZNR-LH	6	3.67	3	0°	1.2	1.3	☆	☆	☆	☆	★	★	★	★							

★ Rec Size ☆ Opt Size
★ 主推型号 ☆ 可选型号

